

截面 A-A

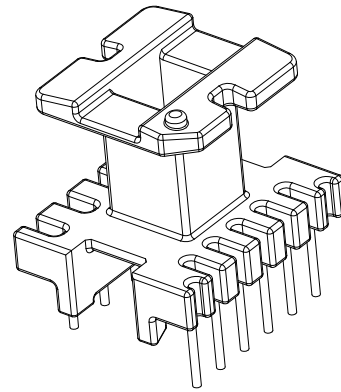
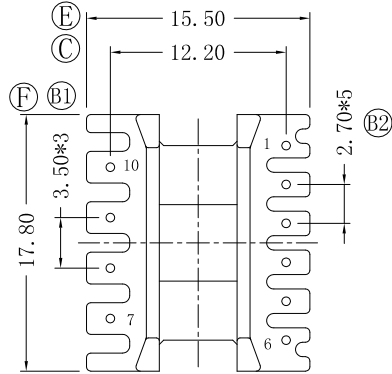
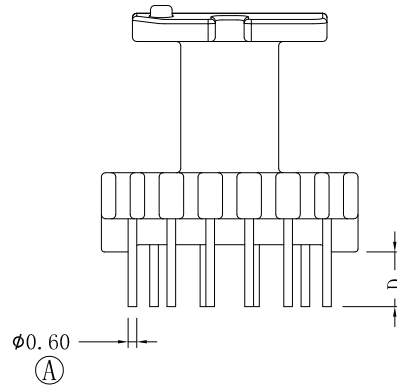
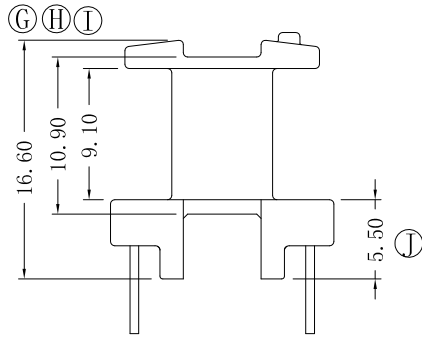

REV.	REVISIONS	REC.	DATE.	REV.	REVISIONS	REC.	DATE.

DRAWN	WZW	TOLERANCES		ANGLE:	TITLE:		
DRAFTED BY		0<L≤4 ±0.1	PIN PITCH	±1°	EI-19		UL REC.
CHECKED	HZP	4<L≤16 ±0.2		UNIT:	MM	BOBBIN MATERIAL:	UL 94V-0
APPROVED BY		16<L≤63 ±0.3	±0.20				
<b>MX</b> 东莞市铭兴电子有限公司 DONG GUAN MING XING ELECTRONICS CO., LTD TEL: 0769-86369622 86011822 FAX: 0769-86369611				SCALE:	TERMINAL MAT:	PIN TENSION LOAD:	
				1/1	CP WIRE	1.0 kg	
				DATE:	DRAWING NO:	REV.	
				2012.09.12	MX-1928	A	