

SECTION A-A

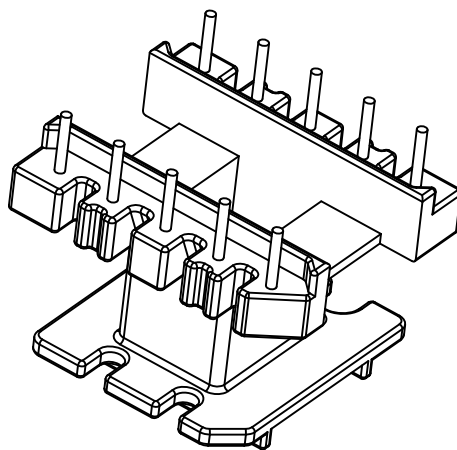
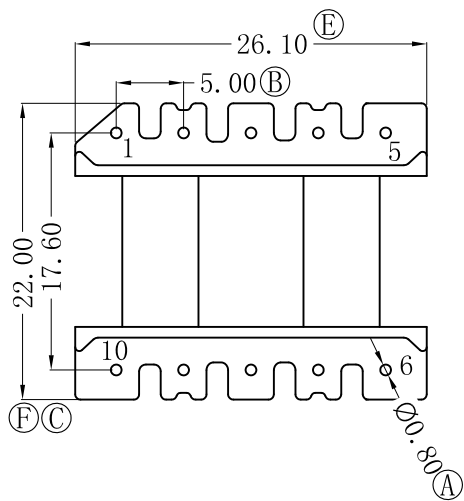
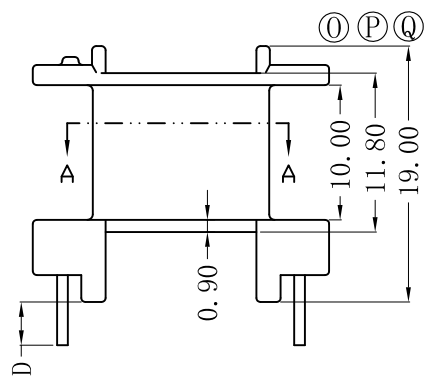
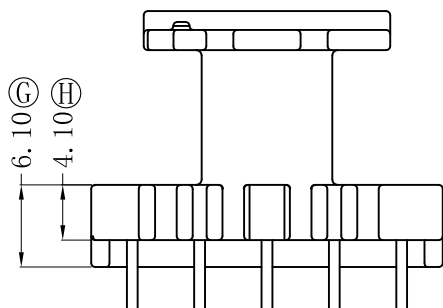

REV.	REVISIONS	REC.	DATE.	REV.	REVISIONS	REC.	DATE.

DRAWN DRAFTED BY	HQH	TOLERANCES		ANGLE:	TITLE:		
		0<L≤4 ±0.1	PIN PITCH ±0.20	±1°	EI-28		UL REC.
CHECKED APPROVED BY	HZP	4<L≤16 ±0.2		壁 厚 ±0.15	UNIT:	BOBBIN MATERIAL:	UL 94V-0
		16<L≤63 ±0.3	MM		PHENOLIC	PIN TENSION LOAD:	
MX 东莞市铭兴电子有限公司 DONG GUAN MING XING ELECTRONICS CO., LTD TEL:0769-86369622 86011822 FAX:0769-86369611				SCALE:	TERMINAL MAT:	DRAWING NO:	
				1/1	CP WIRE	2013.8.5	MX-2827