

版本	修改记录	修改者	修改日期
A	初始发行	SAM	2022.01.17
B	针长改至5.5	QF	2022.04.27

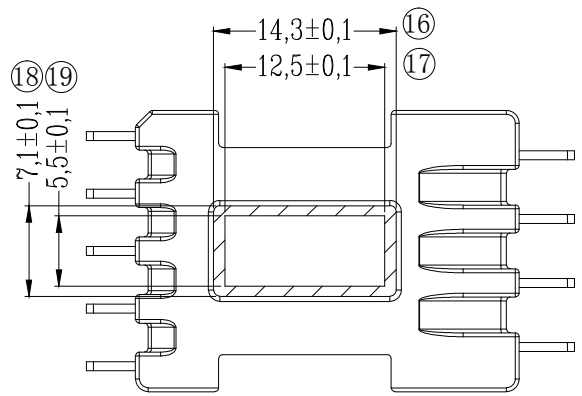
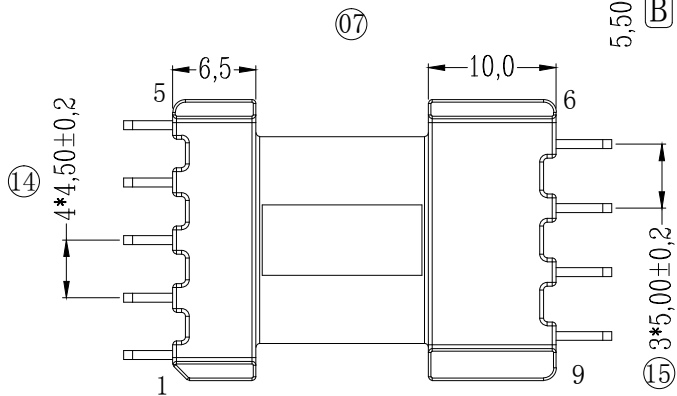
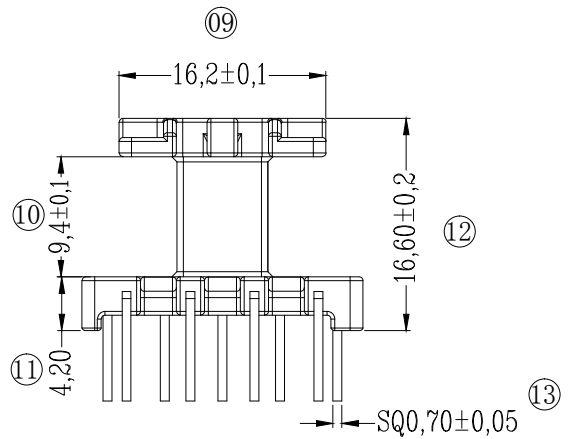
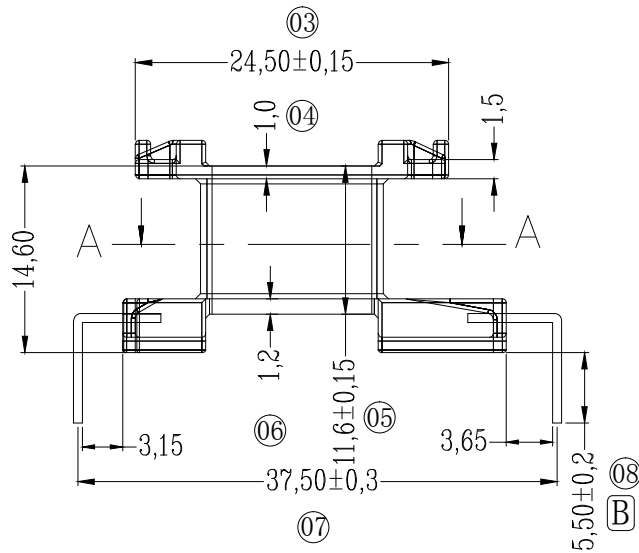
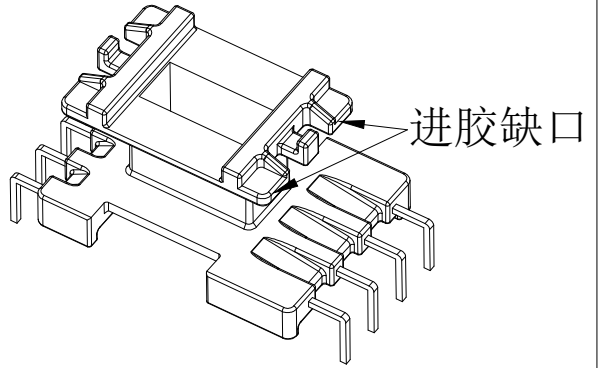
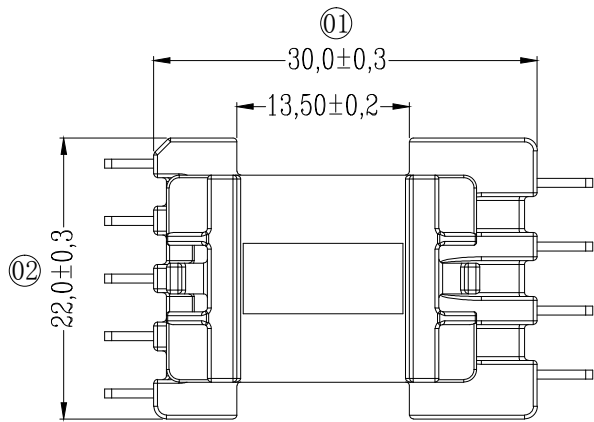
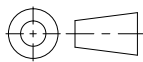

SECTION A-A

MX 东莞市铭兴电子有限公司 DONG GUAN MING XING ELECTRONICS CO., LTD TEL: 0769-86369622 86011822 FAX: 0769-86369611			TITLE: EE22 BOBBIN		
DWN:		TOLERANCES		DRAWING NO: MX-Y2252	
CHKD:		0<L<4 ±0.1 4<L<16 ±0.2 16<L<63 ±0.3 ANGLE: ±0.5°		MATERIAL: T200HF	
APPD:		Wall thickness: ±0.05 PIN PITCH ±0.20		TERMINAL MAT: CP WIRE	
		UNIT: MM		UL REC. UL 94V-0	
					
				REV. B	